

AJAX™ INTEGRAL ENGINE-COMPRESSOR DPC-2801

192 bhp, 440 rpm

Robust, reliable Ajax engines have been manufactured in the United States longer than any other OEM brand engines, with continuous innovations and technologies adding compliance, strength and simplicity to the original design. The DPC-2801 integral engine compressor is rated at 192 bhp and features a slow-speed, two-cycle engine design that results in less wear and fewer moving parts. It offers greater reliability and efficiency than high-speed separable units. As a result, operating costs are substantially lower over the life of your equipment. Over 190 DPC-2801s have been built. The DPC-2801 is the economic choice for a variety of applications, including gas gathering, injection, processing, transmission, and fuel gas boosting.

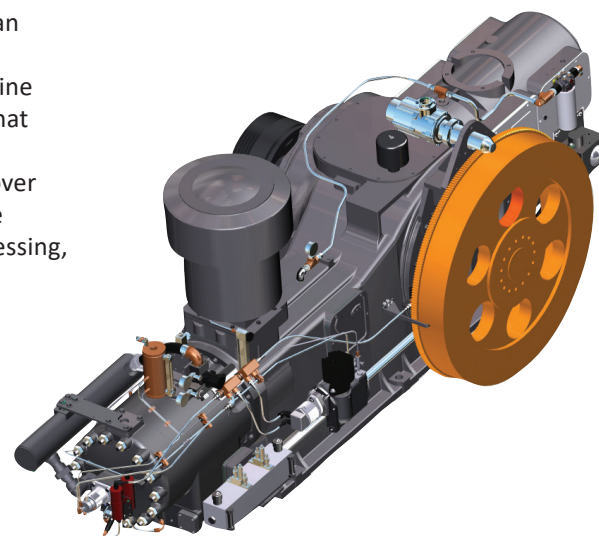

Benefits

- > Minimum maintenance
- > Higher availability
- > Higher resale value
- > Reduced parts stocking requirements
- > Single source responsibility available
- > More gas compressed per BHP than high-speed separable units
- > Higher mechanical efficiency
- > Flexible

Features

- > Integral crankshaft design
- > Slow operating speed
- > Fewer moving parts
- > Technically current design
- > Low-cycle, low BMEP engine
- > Larger valve area

Model	STD	LE
No. of Cylinders	1	1
Power	192 bhp (143 kWb)	192 bhp (143 kWb)
Rated Speed	440 rpm	440 rpm
Bore & Stroke	15" x 16" (381 mm x 406 mm)	15" x 16" (381 mm x 406 mm)
Piston Displacement	2,827 in ³ (46 l)	2,827 in ³ (46 l)
BMEP	61.1 psi (4.2 bar)	61.1 psi (4.2 bar)
Piston Speed	1,173 ft/min (6 m/s)	1,173 ft/min (6 m/s)

LEGENDS DON'T STOP. WE MAKE SURE OF IT.™

CALL +1-844-RECIP-43 (INTERNATIONAL: +1-713-354-1299)
 24/7 TECH SUPPORT: SUPPORT@COOPERSERVICES.COM
 COOPERSERVICES.COM



Model	STD	LE
Fuel Gas System¹		
Fuel pressure range	150 psi (10.3 bar)	150 psi (10.3 bar)
Exhaust System²		
Exhaust Temperature	460°F (238°C)	460°F (238°C)
Exhaust Flow	58 lb/min (26 kg/min)	60 lb/min (27 kg/min)
Cooling Water System		
Capacity	25 gal (95 l)	25 gal (95 l)
Lube Oil System³		
Capacity	25 gal (95 l)	25 gal (95 l)
Consumption	6.4 pints/day (3.0 l/day)	6.4 pints/day (3.0 l/day)
Crankcase Makeup	1.27 pints/day (0.6 l/day)	1.27 pints/day (0.6 l/day)
Brake Specific Fuel Consumption		
100% Load (LHV)	8,200 Btu/bhp-hr (11,602 kJ/kWh)	7,800 Btu/bhp-hr (11,036 kJ/kWh)
Engine Emissions²		
NO _x	5.5 g/bhp-hr	2 g/bhp-hr
CO	1.4 g/bhp-hr	1.2 g/bhp-hr
NMHC	0.7 g/bhp-hr	0.6 g/bhp-hr
VOC	0.5 g/bhp-hr	0.5 g/bhp-hr
Formaldehyde	0.3 g/bhp-hr	0.3 g/bhp-hr
CO ₂	481 g/bhp-hr	458 g/bhp-hr
Compressor Specifications		
No. of Throws	1	1
Stroke	11" (279 mm)	11" (279 mm)
Piston Speed	807 ft/min (4 m/s)	807 ft/min (4 m/s)
Rod Load	30,000 lb (133 kN)	30,000 lb (133 kN)
Rod Diameter	2.5" (64 mm)	2.5" (64 mm)
Crankshaft Centerline	20" (508 mm)	20" (508 mm)
Dry Weight		
Frame Weight	11,000 lb (4,990 kg)	11,000 lb (4,990 kg)
Dimensions		
Frame Length	158" (4,013 mm)	158" (4,013 mm)
Frame Width	61" (1,549 mm)	61" (1,549 mm)
Frame Height	53" (1,346 mm)	53" (1,346 mm)
Stack Diameter	13¼" (337 mm)	13¼" (337 mm)
Stack Height	256" (6,502 mm)	256" (6,502 mm)
Flywheel		
Outside Diameter	48" (1,219 mm)	48" (1,219 mm)
Weight	2,200 lb (998 kg)	2,200 lb (998 kg)

¹ Fuel gas system pressure noted is maximum pressure at customer connection

² Exhaust and emissions noted based on: PLQNG, 1500 FASL elevation, 65°F ambient temperature for STD and LE

³ Lube oil system consumption rates based on full load and full speed operation. Values do not indicate break-in consumption rates.

LEGENDS DON'T STOP. WE MAKE SURE OF IT.™

CALL +1-844-RECIP-43 (INTERNATIONAL: +1-713-354-1299)
 24/7 TECH SUPPORT: SUPPORT@COOPERSERVICES.COM
 COOPERSERVICES.COM

